

# 6mm Ceramic Trimmer Capacitor

6mm series is tough constructed ceramic trimmer capacitor without a center axis and the unique doubt encased type against shock in automatic assembly. The rotor in the case is arranged to turn a quite smoothly, featuring wide range of nominal capacitance.

## Features

- \* Color-coded case permits easy identification
- \* Sealed construction prevents the penetration of flux and dust
- \* Wide range of nominal capacitance
- \* +(cross-shaped) slot enables automatic adjustment

## Specifications

- \* Operation Temperature Range: -25°C to +85°C
- \* Working Voltage: 100VDC
- \* Withstanding Voltage: 220VDC
- \* Insulation Resistance: 100,000 Mohm min
- \* Rotation Torque: 30-100gf/cm
- \* Soldering Temperature: 260°C +/-5°C

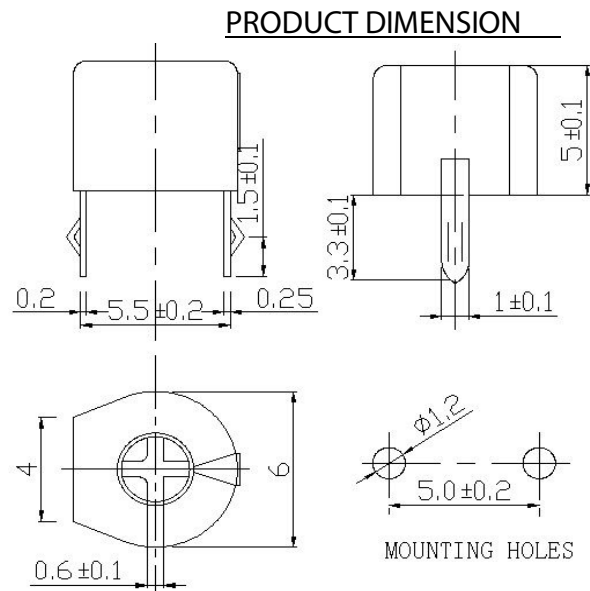

Part No.	Capacitance(pF)			Q (1MHz, Cmax)	Temp.Coeff ppm/°C	Rated Voltage	Withstanding Voltage	Color Code
	Min	Max.						
KCT 1.3-03.0	1.3 max	3	+ 50% - 0%	500 min	NP 0±200	100Vdc	220Vdc	Blue
KCT 2.3-05.0	2.3 max	5	+ 50% - 0%		NP 0±250	100Vdc	220Vdc	Blue
KCT 2.5-07.0	2.5 max	7	+ 50% - 0%		NP 0±250	100Vdc	220Vdc	Blue
KCT 3.0-10.0	3.0 max	10	+ 50% - 0%		N 450±300	100Vdc	220Vdc	White
KCT 4.5-20.0	4.5 max	20	+ 50% - 0%		N 750±300	100Vdc	220Vdc	Red
KCT 6.0-30.0	6.0 max	30	+ 50% - 0%		N 1000±500	100Vdc	220Vdc	Green
KCT 8.0-40.0	8.0 max	40	+ 50% - 0%	300 min	N 1200±500	100Vdc	220Vdc	Yellow
KCT10.0-50.0	10.0 max	50	+ 50% - 0%	200 min	N 1200±500	100Vdc	220Vdc	Brown
KCT12.0-60.0	12.0 max	60	+ 50% - 0%		N 1200±800	100Vdc	220Vdc	Brown
KCT14.0-70.0	14.0 max	70	+ 50% - 0%		N 2200±800	50Vdc	110Vdc	Brown
KCT26.0-90.0	26.0 max	90	+ 50% - 0%		N 2200±800	50Vdc	110Vdc	Brown

# 6mm Ceramic Trimmer Capacitor

## Applications

These specifications are applied to Ceramic Trimmer Capacitors with the ceramic dielectric, which are used for the electric and electronic apparatus and communication equipments.

## Electrical Characteristic

### 1. Capacitance Drift After Adjustment

Rotation shall be made for 5 cycles for 180° at a rate of 20 r/mm, a capacitance value difference would be found immediately. Once the shaft is stopped at the position of the maximum capacitance value after 24 hours later. The specification range should be within 5pF, 10pF ± 1.5% and 30pF ± 2%

### 2. Capacitance

When measured at 2°C, 0.5V to 5V, and 1MHz, the minimum capacitance is smaller than the minimum nominal capacitance and the maximum capacitance is bigger than the maximum nominal capacitance, Please refer to the minimum and maximum capacitances listed in the attached specification.

### 3. Temperature Characteristics

When measured the capacitance at 1MHz±10%, it reached the heat balance at each temperature changed to +20°C to -25°C to +20°C to -20°C with adjusting to 80%~90% of the maximum capacitance, the capacitor change is based on the capacitance at +°C of 2nd stage of changing the temperature as above

Step	1	2	3	4	5
Temperature(°C)	20±2	- 25±2	20±2	85±2	20±2

$$TC = \frac{(C_2 - C_1) * 10^6}{(T_2 - T_1) * C_1}$$

TC : Temperature coefficient at T<sub>2</sub> (ppm/°C)

C<sub>1</sub> : Initial capacitance value at step 3 (pF)

C<sub>2</sub> : Capacitance at specified temperature

T<sub>1</sub> : 20°C (step 3)

T<sub>2</sub> : Test temperature (step 2 or 4)

### 4. Q (Quality factor)

When measured at 2°C, 0.5V to 5V, 1MHz and maximum capacitance, the Q values are listed in the attached specification.

### 5. Insulation Resistance

When applied 100VDC between terminals for 1 minute at the maximum capacitance, the insulation resistance shall be more than 10,000MΩ.

# 6mm Ceramic Trimmer Capacitor

## 6. Withstanding Voltage

There is no abnormality after applied 220VDC (less than 5mA) for 5 seconds between the terminals.

## Structure and mechanical characteristics

### 1. Configuration and Dimensions

Please refer to the attached drawings.

### 2. Strength of Terminals

When applied a power to the terminals to any direction slowly and kept at 0.5 kg for 10 seconds, the terminals shall not be loosen or broken mechanically.

### 3. Torque

The torque test should be done at least for 1 round tuning from 50gf/cm to 100gf/cm for the Normal Type, or 15gf.cm to 100gf.cm for the Reverse Type . Please note that it might cause the torque will decrease against the rotation increase.

### 4. Solder ability

When dipped the terminals into the soldering pot at  $255^{\circ}\text{C} \pm 5^{\circ}\text{C}$  for  $2 \pm 0.5$  seconds. There is almost 75% of the total dipped surface are covered with the new solder.

( **Caution:** Keep the soldering conditions as above. If the soldering conditions are not suitable (excessive time, excessive temperature and etc.), it's performance will be seriously deviated. )

## Color Code

Please refer to the color code in the attached specifications.