

U TYPE

REV.	DESCRIPTION	DRAWN	CHECKED	APPROVED
A	NEW RELEASE	LJH 09/15/05'	~	LJC 09/15/05'
B,C,D	ADD DIM.	LJH 04/04/06'	~	LJC 04/04/06'
F	ADD DIM.	LJH 04/15/06'	~	LJC 04/04/06'
G	整理图面	YCH 03/15/07'	~	LJC 03/15/07'
K	整理图面	YCH 08/12/09'	~	

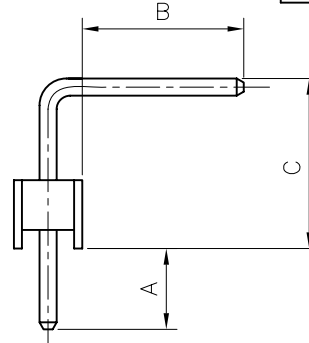
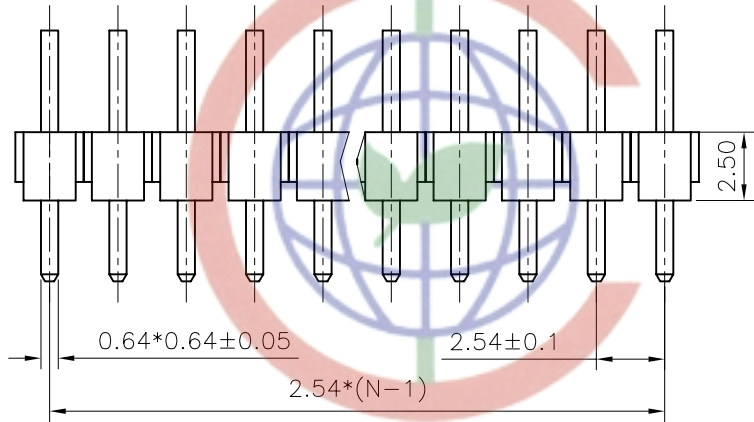

NOTES:

- MATERIALS
 - CONTACT MATERIAL: COPPER ALLOY.
 - INSULATOR: PBT OR PA-46
- SPECIFICATIONS
 - CURRENT RATING: 3A.
 - OPERATING TEMPERATURE: -40°C TO +105°C.
 - INSULATION RESISTANCE: 1000MΩ MIN.
 - CONTACT RESISTANCE: 20mΩ MAX.
 - DIELECTRIC WITHSTANDING: 600 VAC.
- PART NUMBER: DS1022
- PRODUCT NUMBER CODE:

DS1022- X X U X X

Dim. A B C type
 1: Type 1
 26: Type 26
 CONTACT PLATING
 F1: FULL GOLD FLASH
 6: FULL TIN
 BEND TYPE
 U:U TYPE
 MOUNTING TYPE
 R:R/A
 No.OF CONTACTS
 1*1 - 1*40

N: NUMBER OF CONTACTS
 2.54*N REF

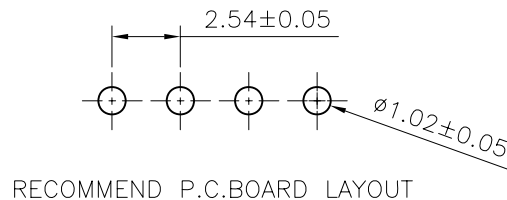
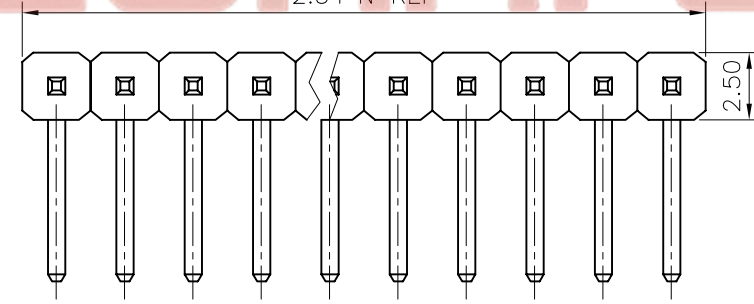

TABLE A:

TYPE	Dimension			Pin Length (mm)
	A	B	C	
1	3.00	6.00	6.07	15.50
2	4.00	6.90	3.40	14.70
3	6.00	11.40	5.64	23.40
4	3.75	3.40	3.40	11.00
5	2.80	4.00	3.40	10.60
6	5.85	7.90	3.40	17.50
7	3.60	3.20	3.40	10.60
8	6.30	3.20	4.36	14.20
9	3.00	6.00	5.42	15.00
10	3.64	5.76	6.48	16.30
11	3.00	6.00	5.00	14.40
12	3.10	3.40	3.40	10.50
13	6.00	4.90	3.40	14.70
14	6.30	3.00	3.40	14.00
15	6.20	3.70	3.60	14.00
16	3.00	6.30	4.20	14.00
17	2.30	5.11	5.30	13.10
18	6.20	3.80	3.40	13.80
19	4.70	4.70	4.20	14.00
20	4.00	6.93	5.50	16.85
21	2.50	5.40	4.50	12.80
22	5.10	3.50	4.00	13.10

普通

23	3.00	4.40	4.00	11.85
24	3.00	4.75	4.00	12.15
25	4.70	4.80	3.70	13.70
26	3.00	12.50	5.00	20.95
27	5.80	4.30	3.34	13.85
28	2.50	5.20	4.30	12.40
29	3.00	6.20	6.45	16.10
30	3.00	6.00	4.30	13.80
31	7.50	7.80	4.00	19.80
32	3.00	7.00	6.07	15.50
33	3.00	6.00	6.57	16.00
34	6.00	4.40	3.68	14.50
35	3.07	5.92	6.50	15.90
36				
37				
38				
39				
40				
41				
42				

31			
32			
33			
34			
35			
36			
37			
38			
39			
40			
41			
42			

GENERAL TOLERANCE	ANGLE TOLERANCE	PROJECTION	TITLE
X. ±0.60	X. ±5°	mm	PIN HEADER PITCH 2.54mm R/A TYPE
.X ±0.38	.X ±3°	A4	SERIES DS1022 SERIES
.XX ±0.25	.XX ±2°		
DRAWING TYPE	CUSTOMER	晨翔电子有限公司 CONNFLY CONNFLY ELECTRONIC CO. LTD	
SCALE	1:1 SHEET 1 OF 1		
DRAWING NO.	C-DS1022-1*XXXUX		

D TYPE

REV.	DESCRIPTION	DRAWN	CHECKED	APPROVED
A	NEW RELEASE	LJH 04/06/06'	~	LJC 04/06/06'
B	ADD DIM	LL 08/05/06'	~	LJC 04/06/06'
C	增加规格整理图面	YCH 03/15/07'	~	LJC 03/15/07'
J	整理料号	YCH 04/23/08'	~	

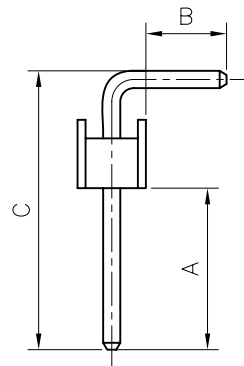
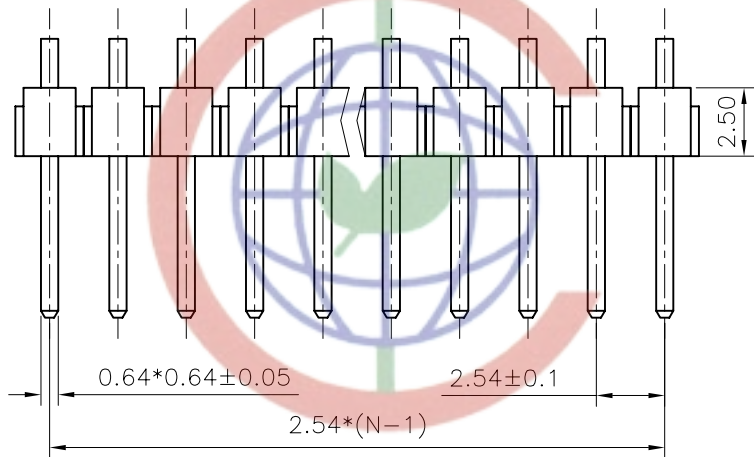

NOTES:

- MATERIALS
 - 1.1 CONTACT MATERIAL: COPPER ALLOY.
 - 1.2 INSULATOR:PBT OR PA-46
- SPECIFICATIONS
 - 2.1 CURRENT RATING: 3A.
 - 2.2 OPERATING TEMPERATURE: -40°C TO +105°C.
 - 2.3 INSULATION RESISTANCE: 1000MΩ MIN.
 - 2.4 CONTACT RESISTANCE: 20mΩ MAX.
 - 2.5 DIELECTRIC WITHSTANDING: 600 VAC.
- PART NUMBER: DS1022
- PRODUCT NUMBER CODE:

DS1022- X X D X X

Dim. A B C type
 1: Type 1
 22: Type 22

 CONTACT PLATING
 F1: FULL GOLD FLASH
 6: FULL TIN
 BEND TYPE
 D:D TYPE
 MOUNTING TYPE
 R:R/A
 No.OF CONTACTS
 1*1 - 1*40

TABLE A:

TYPE	Dimension			Pin Length (mm)
	A	B	C	
1	6.00	3.00	10.36	13.80
2	6.00	4.50	9.50	14.40
3	6.10	4.00	10.40	14.80
4	6.00	3.20	10.50	14.10
5	6.00	3.50	10.82	14.70
6	4.70	1.73	8.20	10.40
7	15.00	3.00	19.08	22.50
8	6.00	3.10	11.10	14.40
9	1.00	1.91	5.00	7.40
10	6.20	3.20	11.10	14.70
11	6.20	3.20	10.8	14.40
12	4.50	2.93	8.00	11.40
13	6.30	2.60	10.36	13.40
14	5.70	2.95	9.52	12.90
15	4.80	3.00	8.10	11.50
16	6.00	3.00	9.14	12.60
17	7.20	3.00	10.36	13.80
18	3.00	6.00	7.50	13.80
19	3.00	6.00	9.32	15.80
20	3.50	3.00	7.86	11.30

普通

21	5.00	2.70	8.14	11.30
22	8.20	2.80	12.30	15.50
23	3.00	3.00	7.36	10.80
24	6.50	3.00	10.36	13.80
25	6.80	8.40	10.64	19.50
26				
27				
28				
29				
30				
31				
32				
33				
34				
35				
36				
37				
38				

①

39				
40				
41				
42				
43				
44				
45				
46				
47				
48				
49				

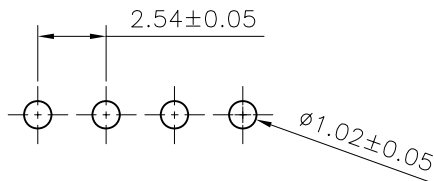
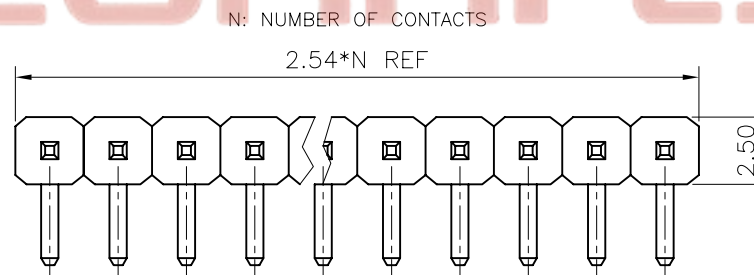

RECOMMEND P.C.BOARD LAYOUT

A/B/C: CUSTOMER LENGTH AVAILABLE

GENERAL TOLERANCE		ANGLE TOLERANCE		PROJECTION	TITLE
X.	±0.60	X.	±5°	mm	PIN HEADER PITCH 2.54mm R/A TYPE
.X	±0.38	.X	±3°	A4	SERIES DS1022 SERIES
.XX	±0.25	.XX	±2°		
DRAWING TYPE	CUSTOMER				
SCALE	1:1	SHEET	1 OF 1		
DRAWING NO.	C-DS1022-1*XXXDX				

晨翔电子有限公司
CONNFLY CONNFLY ELECTRONIC CO. LTD

REV.	DESCRIPTION	DRAWN	CHECKED	APPROVED
A	NEW RELEASE	LJH 09/21/05'	~	LJC 09/21/05'
B,C	ADD DIM.	LJH 04/04/06'	~	LJC 04/04/06'
D	ADD DIM.	LL 09/26/06'	~	LJC 09/26/06'
E	整理图面	YCH 03/15/07'	~	LJC 03/15/07'
F	增加SMT尺寸值表格	YCH 05/18/07'	~	LJC 05/18/07'
G	整理图面	YCH 07/23/08'	~	LJC 07/23/08'
H	去除SMT类型	YCH 05/28/09'	~	

RIGHT ANGLE TYPE
N:NUMBER OF CONTACT/2

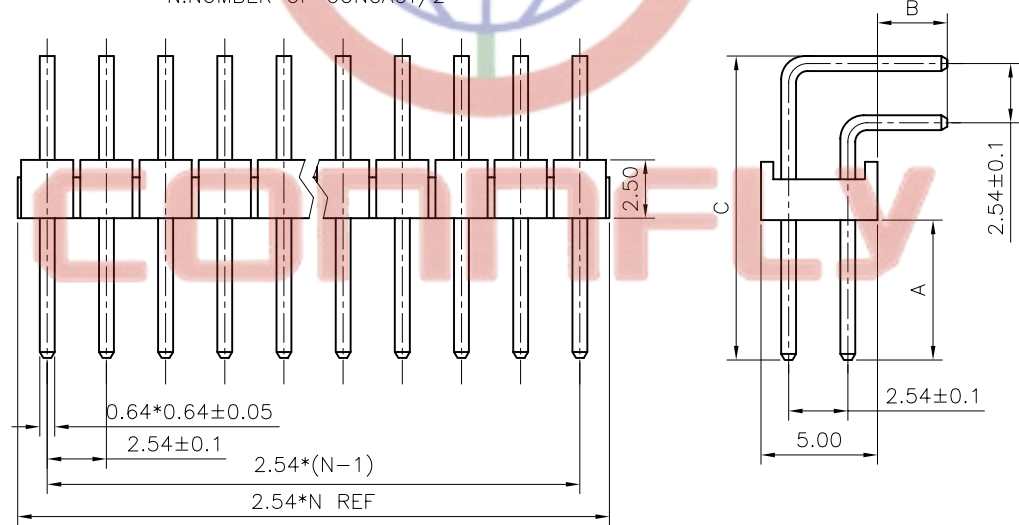

RIGHT ANGLE
TABLE A:

TYPE	Dimension			Pin Length (mm)
	A	B	C	
1	6.00	3.00	13.04	14.00 19.00
2	6.10	4.00	12.94	14.80 19.90
3	6.00	4.00	12.76	14.70 19.70
4	9.00	3.00	16.04	16.90 22.00
5	6.00	3.00	13.80	14.70 19.80
6	5.10	3.00	13.04	14.00 19.00
7	6.50	3.00	13.10	14.00 19.00

NOTES:

- MATERIAL
 - CONTACT MATERIAL: COPPER ALLOY.
 - INSULATOR:PBT OR PA-46
- SPECIFICATION
 - STORAGE TEMPERATURE: -20-70°C.
 - OPERATING TEMPERATURE: 0-85°C.
 - CONTACT RESISTANCE: 20mΩ max.
 - INSULATION RESISTANCE:1000MΩ min.
 - DIELECTRIC WITHSTANDING VOLTAGE: AC 500V PER MINUTE.
- PART NUMBER: DS1022
- PRODUCT NUMBER CODE:
 DS1022- X X X- X
 Dim. A B C type
 1: Type 1
 7: Type 7
 CONTACT PLATING
 F1: FULL GOLD FLASH
 6: FULL TIN
 MOUNTING TYPE
 R: RIGHT ANGLE
 No. OF CONTACTS
 2*2 - 2*40
 3*2 - 3*40

Tel: 86-574-63508787

Fax: 86-574-63510817

GENERAL TOLERANCE		ANGLE TOLERANCE		PROJECTION	⊕	TITLE	PIN HEADER PITCH 2.54mm R/A TYPE	
X.	±0.60	X.	±5'	UNITS	mm			
.X	±0.38	.X	±3'	SHEET SIZE	A4	SERIES	DS1022 SERIES	
.XX	±0.25	.XX	±2'					
DRAWING TYPE	CUSTOMER							
SCALE	1:1	SHEET	1 OF 1					
DRAWING NO.	C-DS1022-2*XXX-X-G							



晨翔电子有限公司
CONNFLY CONNFLY ELECTRONIC CO. LTD

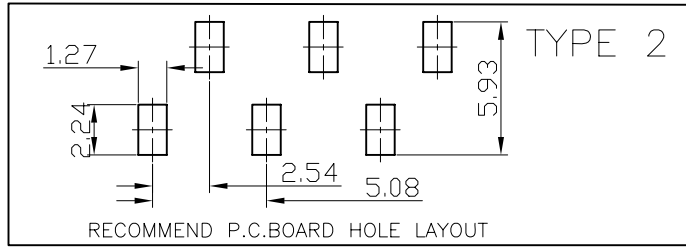
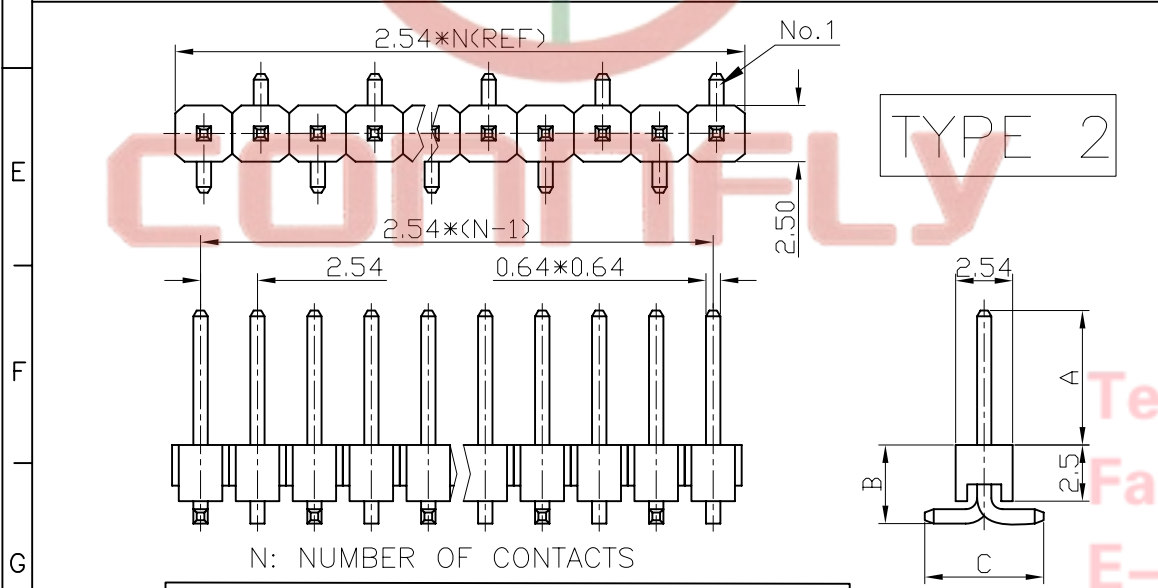
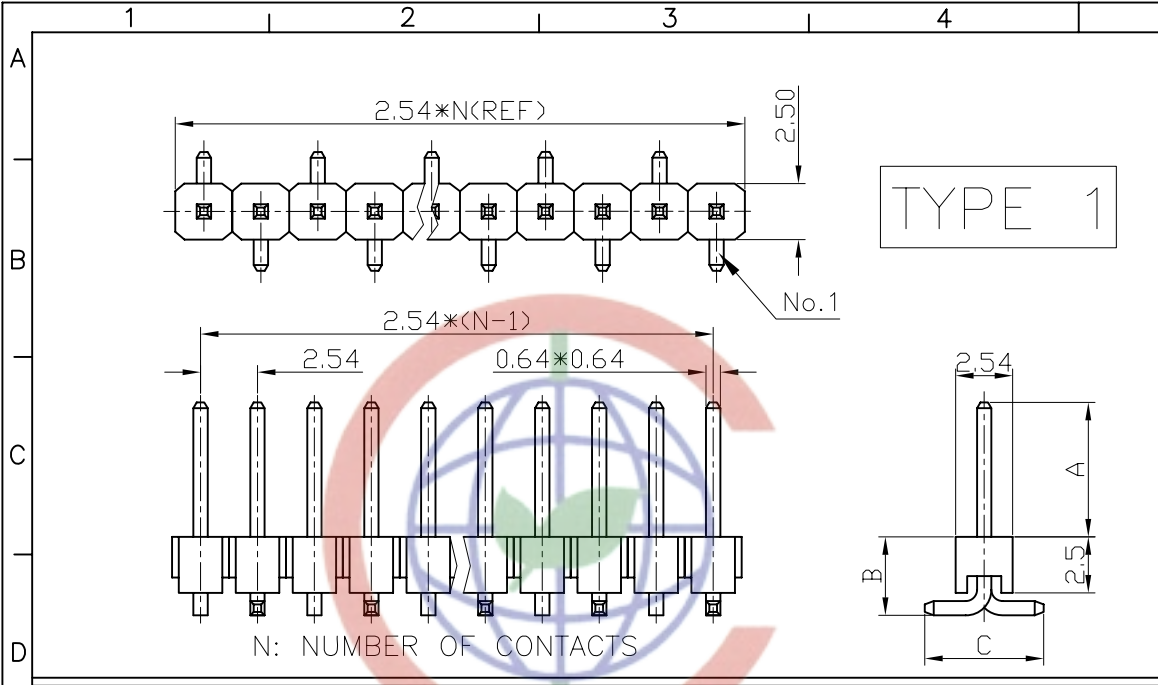

REV.	DESCRIPTION	DRAWN	CHECKED	APPROVED
A	NEW RELEASE	YCH 01/18/08'	~	

- NOTES:
- MATERIALS
 - CONTACT MATERIAL: COPPER ALLOY.
 - CONTACT PLATING: GOLD/TIN OVER NICKEL.
 - INSULATOR MATERIALS: PA-46(black) 30% G.F.
 - SPECIFICATIONS
 - CURRENT RATING: 3 A.
 - OPERATING TEMPERATURE: -40°C TO +105°C.
 - INSULATION RESISTANCE: 1000MΩ MIN.
 - CONTACT RESISTANCE: 20mΩ MAX.
 - DIELECTRIC WITHSTANDING : 600 VAC.
 - CONTACT INSERTION FORCE PER PIN: 1kgf min.
 - PRODUCT NUMBER CODE:

TABLE A:

TYPE	Dimension			Pin Length (mm)
	A	B	C	
1	6.00	3.50	5.30	11.30
2	6.00	4.30	4.90	11.90
3				
4				
5				
6				
7				
8				
9				
10				
11				
12				
13				
14				
15				
16				
17				
18				
19				
20				
21				
22				
23				
24				
25				
26				
27				
28				
29				
30				
31				
32				
33				
34				

普通

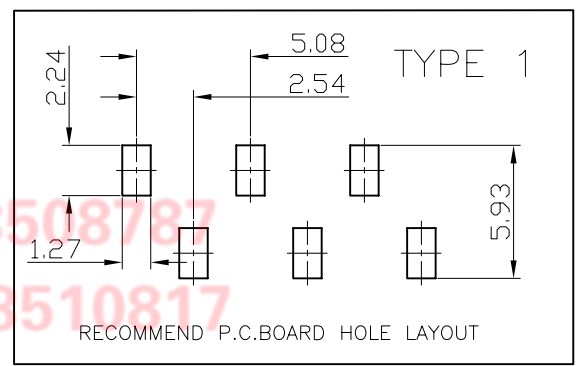
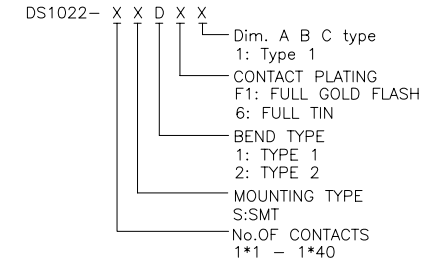

GENERAL TOLERANCE	ANGLE TOLERANCE	PROJECTION	TITLE
X. ±0.60	X. ±5°	mm	PIN HEADER PITCH 2.54mm SMT TYPE
.X ±0.38	.X ±3°	A4	SERIES DS1022 SERIES
.XX ±0.25	.XX ±2°		
DRAWING TYPE	CUSTOMER	晨翔电子有限公司 CONNFLY CONNFLY ELECTRONIC CO. LTD	
SCALE	1:1	SHEET	1 OF 1
DRAWING NO.	C-DS1022-1*XXXXX-A		

REV.	DESCRIPTION	DRAWN	CHECKED	APPROVED
A	NEW RELEASE	LJC 03/06/09'		

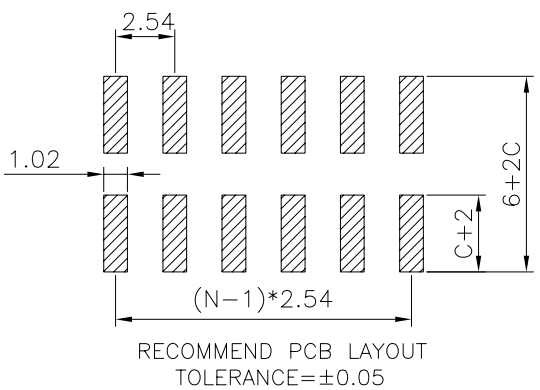
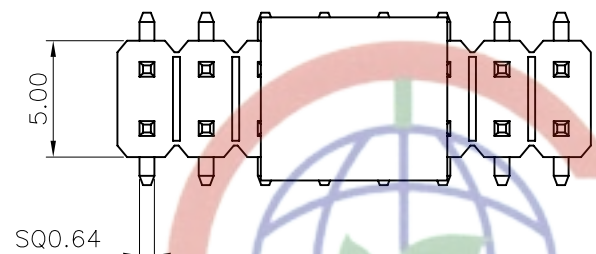

NOTES:

- MATERIAL
 - INSULATOR: PA-46(black) 30% G.F
 - CONTACT: COPPER ALLOY.
- SPECIFICATION
 - TEMPERATURE RANGE: -45 TO +110°C.
 - CURRENT RATING: 3Amp.
 - CONTACT RESISTANCE: 20mΩ max.
 - INSULATION RESISTANCE: 1000MΩ min.
 - DIELECTRIC WITHSTANDING VOLTAGE: AC 600V PER MINUTE.

3. PRODUCT NUMBER CODE:

DS1022- X X X- X X X

PACKING TYPE
 T: TRAY
 R: TAPE ON REEL
 B: TUBE
 A: POLYBAG

PICK UP SUPPORT
 S: W/ PICK UP
 X: W/O PICK UP

Dim. A B C type
 1: Type 1
 3: Type 3

CONTACT PLATING
 F1: FULL GOLD FLASH
 6: FULL TIN

MOUNTING TYPE
 M: SMT

No. OF CONTACTS
 2*2 - 2*40

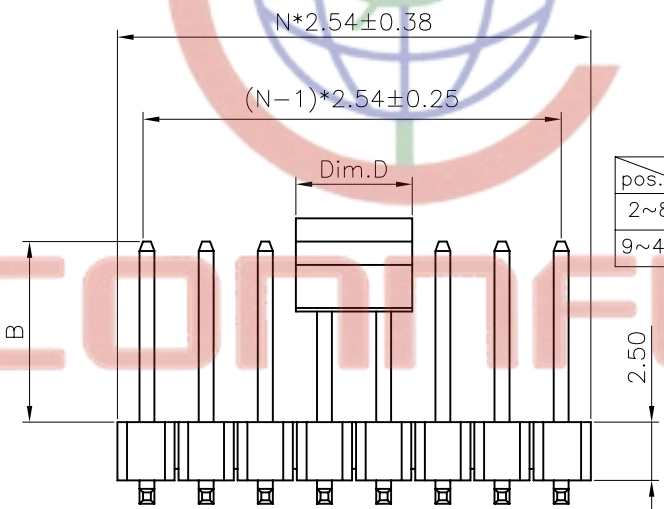

pos.	Dim.	Dim.D
2~8pin		5.0mm
9~40pin		8.0mm

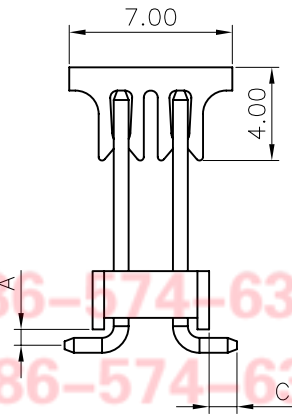
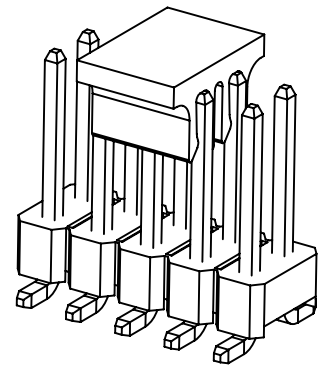

TABLE B:

TYPE	Dimension			Pin Length (mm)
	A	B	C	
1	1.50	6.00	3.00	13.80
2	1.20	6.00	3.00	13.50
3	0.68	7.75	1.20	12.90



GENERAL TOLERANCE	ANGLE TOLERANCE	PROJECTION	TITLE	PIN HEADER PITCH 2.54mm
X. ±0.60	X. ±5'	mm		SMT TYPE
.X ±0.38	.X ±3'	A4	SERIES	DS1022 SERIES
.XX ±0.25	.XX ±2'			
DRAWING TYPE	CUSTOMER	晨翔电子有限公司 CONNFLY CONNFLY ELECTRONIC CO. LTD		
SCALE	1:1	SHEET	1 OF 1	
DRAWING NO.	C-DS1022-2*XXMX-XX-A			