

REV.	DESCRIPTION	DRAWN	CHECKED	APPROVED
A	NEW RELEASE	LJH 03/30/06'	~	LJC 03/30/06'
B	整理图纸	YCH 10/18/10'	~	

NOTES:

- ELECTRICAL CHARACTERISTICS:
  - CONTACT RESISTANCE: 20mΩ Max. INITIAL.
  - DIELECTRIC WITHSTANDING VOLTAGE: 500V AC(rms) FOR 1 MINUTE.
  - INSULATION RESISTANCE: 1000MΩ Min.
- ENVIRONMENT CHARACTERISTICS:
  - OPERATING TEMPERATURE: 0°C~+85°C.
  - STORAGE TEMPERATURE: -20°C~+70°C.

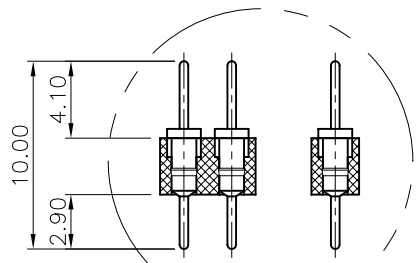

TYPE 1

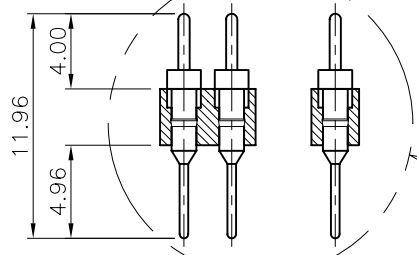

TYPE 2

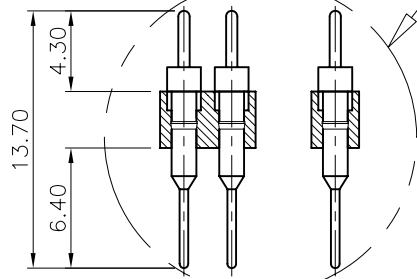

TYPE 3

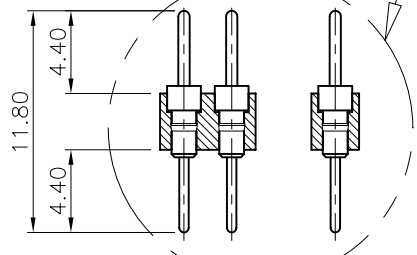

TYPE 4

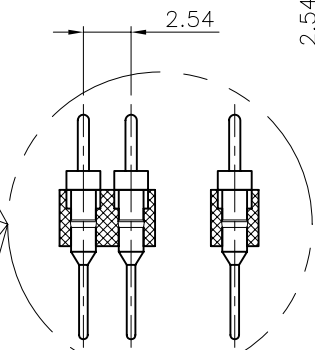

DUAL ROW SINGLE ROW

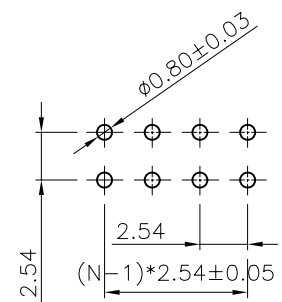
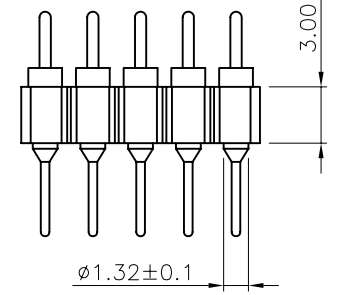
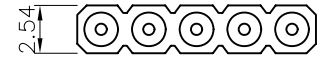
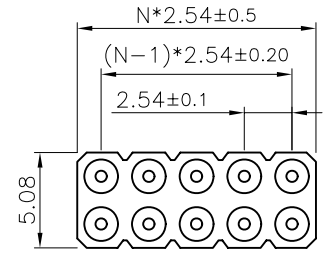

RECOMMEND PCB LAYOUT (TOLERANCE=±0.05)

TYPE1/2/3/4 DIA. (TOLERANCE=±0.05)

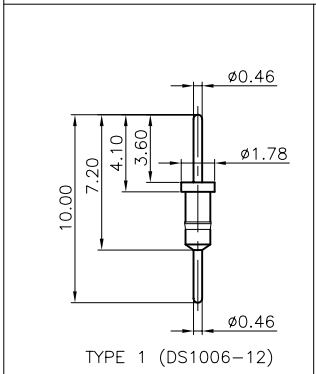

TYPE 1 (DS1006-12)

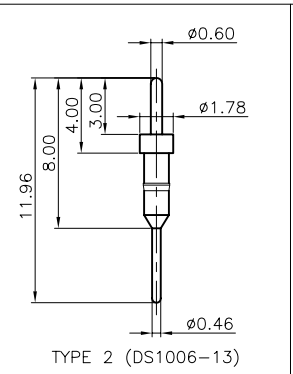

TYPE 2 (DS1006-13)

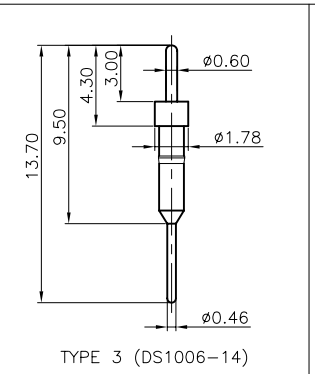

TYPE 3 (DS1006-14)

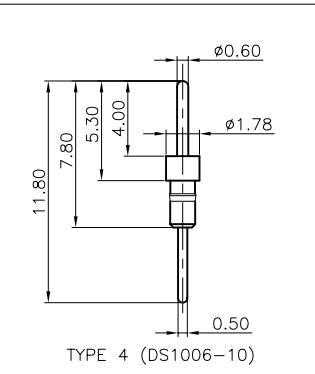

TYPE 4 (DS1006-10)

GENERAL TOLERANCE		ANGLE TOLERANCE		PROJECTION		TITLE	DIP STRIP ADAPTER PITCH 2.54mm	
X.	±0.60	X.	±5°	UNITS		mm		
.X	±0.38	.X	±3°	SHEET SIZE	A4	SERIES		
.XX	±0.25	.XX	±2°					
DRAWING TYPE		CUSTOMER						
SCALE	1:1	SHEET	10F1					
DRAWING NO.								

3: TYPE 3  
4: TYPE 4